

Electro-Hydro. Circuit - JumboZ -500E - PTO with Joystick

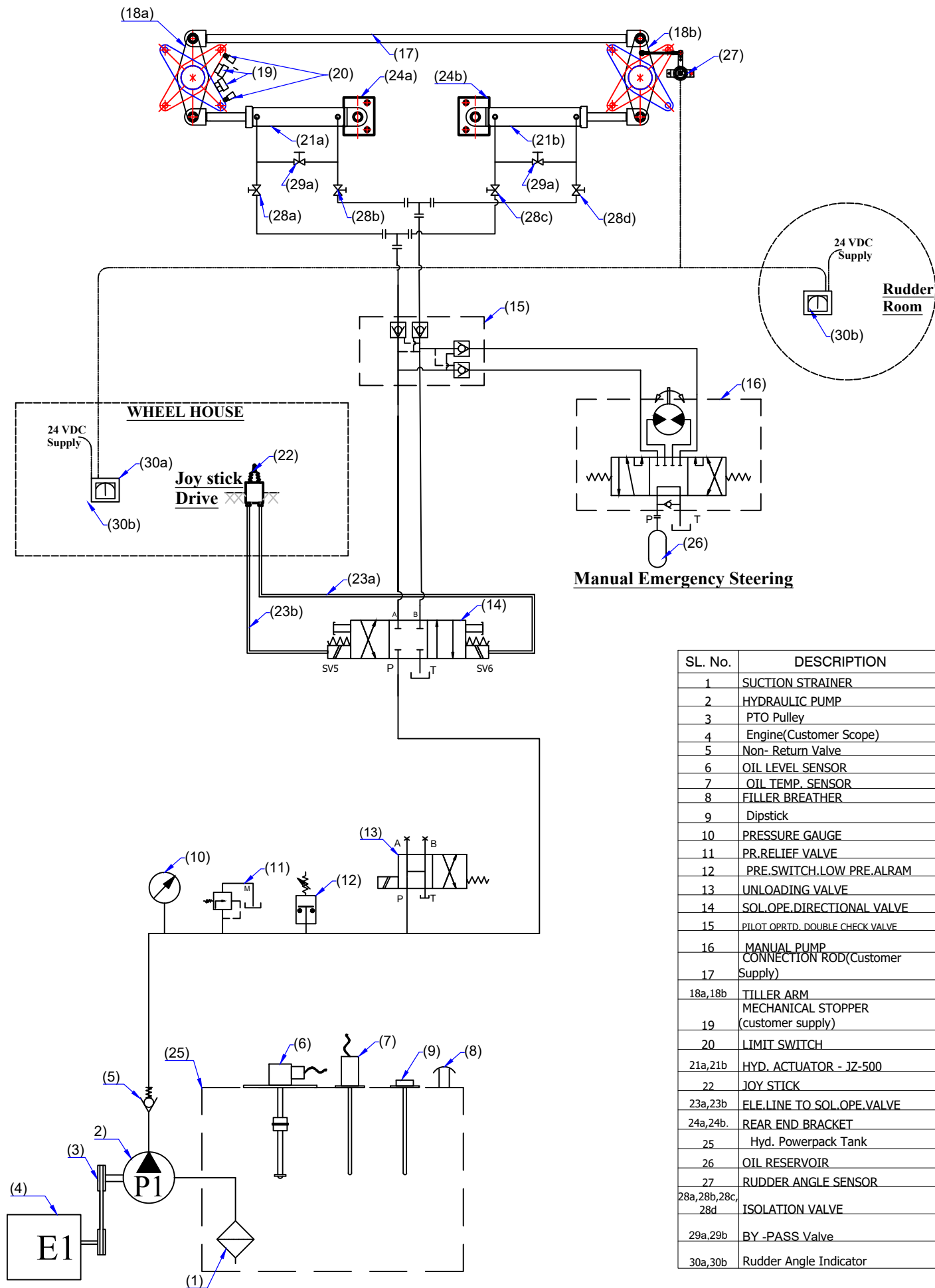

SL. No.	DESCRIPTION
1	SUCTION STRAINER
2	HYDRAULIC PUMP
3	PTO Pulley
4	Engine(Customer Scope)
5	Non- Return Valve
6	OIL LEVEL SENSOR
7	OIL TEMP. SENSOR
8	FILLER BREATHER
9	Dipstick
10	PRESSURE GAUGE
11	PR.RELIEF VALVE
12	PRE.SWITCH.LOW PRE.ALARM
13	UNLOADING VALVE
14	SOL.OPE.DIRECTIONAL VALVE
15	PILOT OPRTD. DOUBLE CHECK VALVE
16	MANUAL PUMP CONNECTION ROD(Customer Supply)
17	CONNECTION ROD(Customer Supply)
18a,18b	TILLER ARM MECHANICAL STOPPER (customer supply)
19	LIMIT SWITCH
20	HYD. ACTUATOR - JZ-500
21a,21b	JOY STICK
22	ELE.LINE TO SOL.OPE.VALVE
23a,23b	REAR END BRACKET
24a,24b	Hyd. Powerpack Tank
25	OIL RESERVOIR
26	RUDDER ANGLE SENSOR
27	ISOLATION VALVE
28a,28b,28c,28d	BY -PASS Valve
29a,29b	Rudder Angle Indicator
30a,30b	